

Prague Spirals

performance installation for Echofluxx 12 by David Means

Performance System:

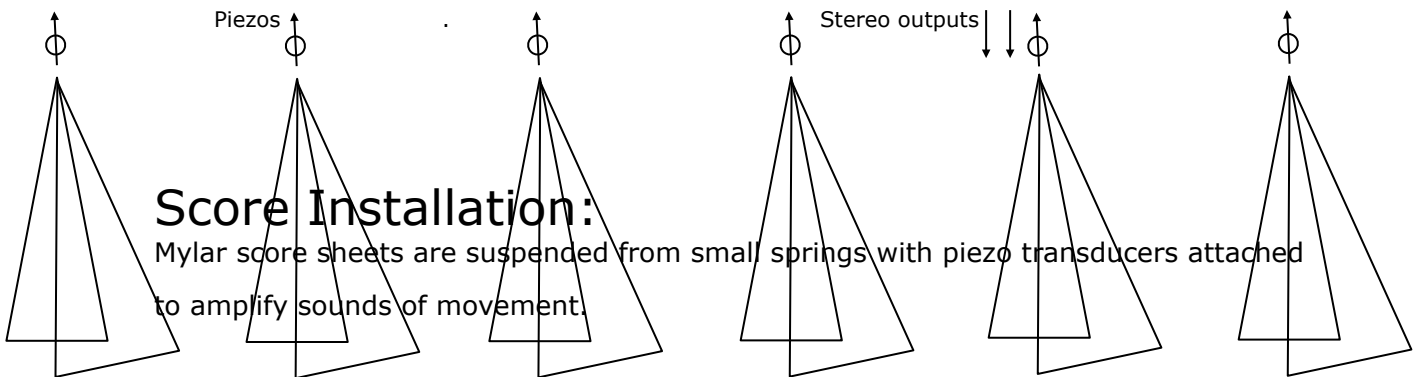
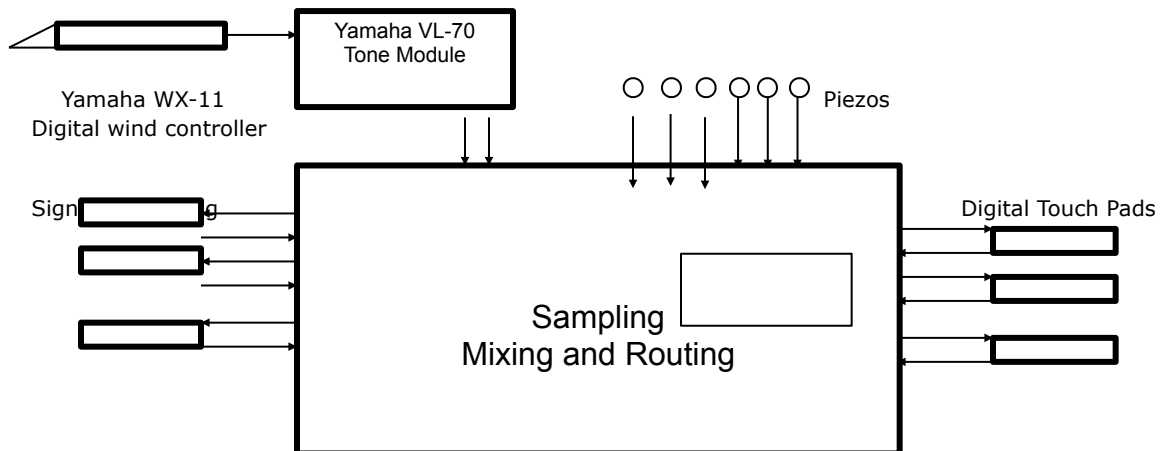

Graphic Score System:

Overlays of graphic score and visual materials suggest a range of interpretation and realization. Variations of traditional pitch and staff notation are elaborated upon and restructured to allow for a broader spectrum of interpretation and realization.

Accidentals occurring after a pitch indicate microtonality.

Clefs and octave transpositions are optional.

Instrumentation and articulations are suggested by graphic notation.

Realization and Performance:

Part or all of any or all six spirals may be exhibited and/or performed in concert or site-specific settings. A version for six laptop computer projections is available for preparation or presentation.